

# NARSWZ04T

## 内螺纹旋启式止回阀 Swing Check Valve 200WOG



### 产品特点 / FEATURES:

多种螺纹端供选择  
Various Thread Standards Available  
旋启式阀瓣  
Swing Disc  
采用脱蜡精密铸造  
Using Dewaxing Precision Casting

### 标准 / STANDARDS:

设计标准 / Design: ASME B16.34  
壁厚标准 / Wall Thickness: ASME B16.34  
螺纹标准 / Pipe Thread: ASME B1.20.1, BS21  
DIN 2999/259, ISO 228/1  
JIS B 0203, ISO 7/1  
检测标准 / Inspection & Testing:  
MSS SP-110, EN 12266

No.	PARTS NAME	MATERIAL		
1	阀瓣/Disc	CF8M	CF8	WCB
2	阀体/Body	VITON		FKM
3	插销/Pin	SUS316	SUS304	
4	垫片/Seat	PFTE		
5	阀盖/Cap	CF8M	CF8	WCB
6	垫圈/Washer	SUS304		
7	双头螺栓/Bolt	SUS304		

Unit:mm

Size	1/2"	3/4"	1"	1-1/4"	1-1/2"	2"
L	60	78	84	94	104	122
Ød	15	20	25	32	40	48
H	41.5	45	49	53.5	58.5	67
C	35	39.5	45	53.5	62	74

# NARSF250

## 内螺纹Y型止回阀 Y Type Check Valve 800WOG

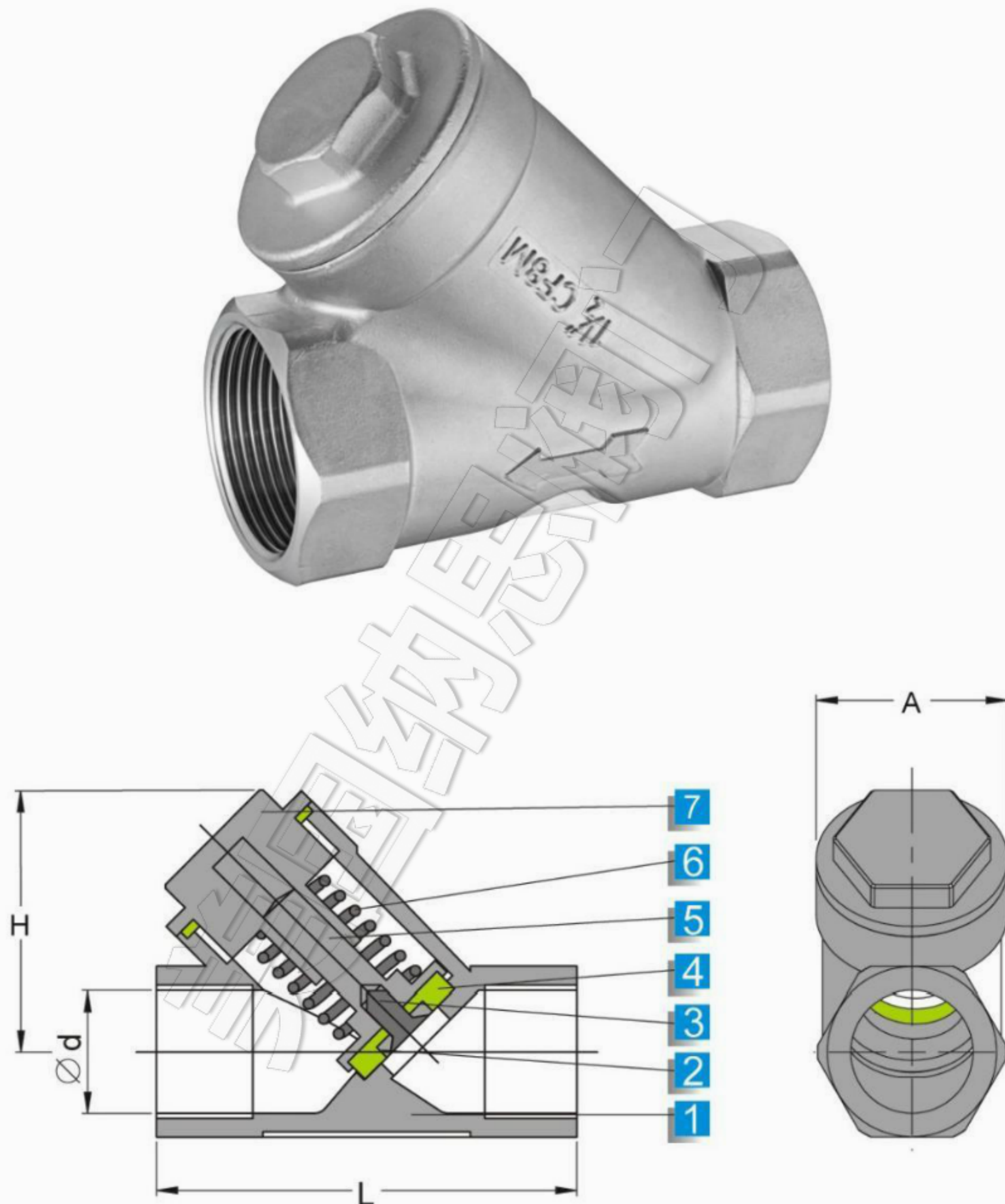

### 产品特点 / FEATURES:

多种螺纹端供选择  
Various Thread Standards Available  
可适宜水平安装及垂直安装  
Suitable For Installation In Horizontal  
And Vertical  
采用脱蜡精密铸造  
Using Dewaxing Precision Casting

### 标准 / STANDARDS:

设计标准 / Design: ASME B16.34  
壁厚标准 / Wall Thickness: ASME B16.34  
螺纹标准 / Pipe Thread: ASME B1.20.1, BS21  
DIN 2999/259, ISO 228/1  
JIS B 0203, ISO 7/1  
检测标准 / Inspection & Testing:  
MSS SP-110, EN 12266

No.	PARTS NAME	MATERIAL	
1	阀体/Body	CF8M	CF8
2	垫圈/Washer	SUS304	
3	螺钉/Screw	GB-T68	
4	阀瓣/Disc	PFTE	METALSEAL
5	阀板/Plate	SUS316	SUS304
6	弹簧/Spring	SUS304	
7	阀盖/Capt	CF8M	CF8

Unit:mm

Size	1/2"	3/4"	1"	1-1/4"	1-1/2"	2"	2-1/2"	3"
L	65	75	90	110	120	140	190	205
Ød	15	20	25	32	38	48	65	78
H	44.7	52.1	65.7	70	79.5	95.5	125	144.5
A	31	36	45	52	61	72	92	107